

Operating and Service Manual
HP 85053B 3.5 mm
Verification Kit

SERIAL NUMBERS

This manual applies directly to HP 85053B Verification
Kits that have serial numbers prefix 2815A.
The verification devices in this kit are individually serialized.



HP Part No. 85053-90028
Printed in USA August 1995

Edition 2

Notice

The information contained in this document is subject to change without notice.

Hewlett-Packard makes no warranty of any kind with regard to this material, including, but not limited to, the implied warranties of merchantability and fitness for a particular purpose. Hewlett-Packard shall not be liable for errors contained herein or for incidental or consequential damages in connection with the furnishing, performance, or use of this material.

Restricted Rights Legend.

Use, duplication, or disclosure by the U.S. Government is subject to restrictions as set forth in subparagraph (c) (1) (ii) of the Rights in Technical Data and Computer Software clause at DFARS 252.227-7013 for DOD agencies, and subparagraphs (c) (1) and (c) (2) of the Commercial Computer Software Restricted Rights clause at FAR 52.227-19 for other agencies.

CERTIFICATION

Hewlett-Packard Company certifies that this product met its published specifications at the time of shipment from the factory. Hewlett-Packard further certifies that its calibration measurements are traceable to the United States National Institute of Standards and Technology (NIST, formerly NBS), to the extent allowed by the institute's calibration facility, and to the calibration facilities of other International Standards Organization members.

WARRANTY

This Hewlett-Packard instrument product is warranted against defects in material and workmanship for a period of one year from date of delivery. During the warranty period, Hewlett-Packard Company will, at its option, either repair or replace products which prove to be defective.

For warranty service or repair, this product must be returned to a service facility designated by HP. Buyer shall prepay shipping charges to HP and HP shall pay shipping charges to return the product to Buyer. However, Buyer shall pay all shipping charges, duties, and taxes for products returned to HP from another country.

HP warrants that its software and firmware designated by HP for use with an instrument will execute its programming instructions when properly installed on that instrument. HP does not warrant that the operation of the instrument, or software, or firmware will be uninterrupted or error free.

LIMITATION OF WARRANTY

The foregoing warranty shall not apply to defects resulting from improper maintenance by Buyer, Buyer-supplied software or interfacing, unauthorized modification or misuse, operation outside of the environmental specifications for the product, or improper site preparation or maintenance.

NO OTHER WARRANTY IS EXPRESSED OR IMPLIED. HP SPECIFICALLY DISCLAIMS THE IMPLIED WARRANTIES OR MERCHANTABILITY AND FITNESS FOR A PARTICULAR PURPOSE.

EXCLUSIVE REMEDIES

THE REMEDIES PROVIDED HEREIN ARE BUYER'S SOLE AND EXCLUSIVE REMEDIES. HP SHALL NOT BE LIABLE FOR ANY DIRECT, INDIRECT, SPECIAL, INCIDENTAL, OR CONSEQUENTIAL DAMAGES, WHETHER BASED ON CONTRACT, TORT, OR ANY OTHER LEGAL THEORY.

ASSISTANCE

Product maintenance agreements and other customer assistance agreements are available for Hewlett-Packard Products.

For any assistance, contact your nearest Hewlett-Packard Sales and Service Office. Addresses are provided at the back of this manual.

Contents

1. General Information	
Verification Kit Overview	1-1
Equipment Required but Not Supplied	1-2
Verification Data Replacement	1-2
Serial Numbers	1-2
Device Serial Numbers	1-3
Incoming Inspection	1-3
Precision Slotless Connectors	1-4
Precision slotless connectors have the following characteristics:	1-4
Preventive Maintenance	1-5
2. Specifications	
Environmental Requirements	2-1
Temperature – What To Watch Out For	2-1
Mechanical Characteristics	2-2
Center Conductor Protrusion	2-2
3. Duplicating Your Verification Data	
Duplicating the Verification Disk Using an HP 8510C	3-1
Duplicating the Verification Tape (option 002) Using an HP 8510A/B	3-2
Duplicating the Verification Disk Using an HP 8719 and HP 8720-series	3-3
Using the Series 200/300 Controller:	3-3
Using the HP 8719 and HP 8720	3-4
4. Gaging and Making Connections	
Electrostatic Discharge	4-1
Visual Inspection	4-1
Obvious Defects or Damage	4-2
Mating Plane Surfaces	4-2
Precision Slotless Connectors	4-2
Connector Wear	4-2
Cleaning Connectors	4-3
Specifications	4-3
Supplemental Characteristics	4-3
Center Conductor Protrusion	4-3
Center Conductor Recession	4-3
Gaging Connectors	4-6
Gage Intent	4-6
Gage Accuracy	4-7
When to Gage Connectors	4-7
Zeroing the Gage	4-8
How To Assemble an Airline	4-8

Connect the Airline:	4-9
Gage the Airline	4-12
Disconnect the Airline:	4-15
Connections	4-15
Connection Procedure	4-15
Using the Torque Wrench	4-16
Disconnection Procedure	4-18
Handling and Storage	4-18
5. Performance Verification	
What Recertification Provides	5-1
How Often to Recertify	5-1
Where to Send a Kit for Recertification	5-2
How Hewlett–Packard Verifies the Devices in this Kit	5-2
For Manufacturing:	5-2
For Customer Kit Recertification:	5-2
6. Troubleshooting	
Compatible Network Analyzers	6-1
HP 8719 and HP 8720-series Network Analyzer	6-1
Returning a Kit or Device to HP	6-1
Where To Look For More Information	6-2
7. Replaceable Parts	
Index	

Figures

1-1. Typical Kit Serial Number Label	1-2
4-1. 3.5 mm Attenuators	4-4
4-2. Outer Conductor (Common to Both Airlines)	4-5
4-3. 50 Ω Airline Center conductor	4-5
4-4. 25 Ω Mismatch Airline Center Conductor	4-6
4-5. Airline Center Conductor Placement	4-9
4-6. Equipment Configuration	4-9
4-7. Aligning the Center Conductor	4-11
4-8. Torquing the Connection	4-11
4-9. Gaging the Short Circuit	4-14
4-10. Gaging the Airline	4-14
4-11. Correct Wrench Position	4-17
4-12. Incorrect Wrench Position	4-17
4-13. Using the Torque Wrench	4-17
6-1. Troubleshooting Flowchart	6-3
7-1. Replaceable Parts	7-3

Tables

1-1. Kit and Device Serial Number Record	1-3
2-1. Environmental Requirements	2-1
3-1.	3-5
4-1.	4-4
4-2.	4-5
4-3.	4-5
4-4.	4-6
4-5. Torque Wrench Information	4-16
7-1. Replaceable Parts	7-2

General Information

Verification Kit Overview

The HP 85053B 3.5 mm verification kit is used with an HP 85052 2.4 mm calibration kit, and Network Analyzer such as the HP 8510, HP 8719, or HP 8720 Series.

Use the HP 85053B verification kit to verify that your network analyzer system is working within its specifications, and that you have performed a valid measurement calibration.

The verification kit consists of the following:

- 20 dB attenuator
- 40 dB attenuator
- 25 Ω mismatch airline
- 50 Ω airline
- A data disk that contains factory measured verification data.

Option 002 adds the following:

- A data tape that contains factory measured verification data.

Option 1BP

Adds a MIL-STD 45662A Certificate of Calibration and the corresponding calibration data to the instrument. This option must be ordered when the instrument order is placed.

Option 1BN Adds a MIL-STD 45662A Certificate of Calibration to the instrument. This option must be ordered when the instrument order is placed.

Note

This manual assumes you know proper connector care. If not, refer to “Principles of Microwave Connector Care—Quick Reference Card” located in the back of this manual, refer to Chapter 7 for the HP part number if another copy is needed.

Or, contact your nearest HP sales office for the customer training course: “Understanding Connectors Used With Network Analyzers”.

- HP 85050A +24A (on site)
 - HP 85050A + 24D (at HP sales office)
-

Equipment Required but Not Supplied

The following items are required but not supplied with this kit. *Some* of the items are included in the HP 85052B 3.5 mm calibration kit.

- 3.5 mm connector gage kit.
- 5/16 inch torque wrench 90 N-cm, 8 in-lb.
- 3.5 mm short circuit termination, male (for gaging the airlines).
- 5/16 inch open end wrench – used on the airline wrench flats.
- Microwave connector cleaning supplies.

For all ordering information, refer to Chapter 7, “Replaceable Parts”.

Verification Data Replacement

Verification data is supplied with your HP 87053B Verification Kit. Data disk media are used with HP 8510C network analyzers, and a separate data disk for use with the HP 8719 and HP 8720-series network analyzers. Data on tape (option 002) is used with the HP 8510A/B network analyzers only.

A file containing the verification data for your kit is maintained for one year from the time of initial factory measurement or recertification measurement. If you lose the original data, or the recertification data, contact the nearest HP office listed at the rear of this manual.

Serial Numbers

A serial number label is attached to this verification kit. A typical kit serial number label is shown in Figure 1-1. The first four digits followed by a letter comprise the serial number prefix; the last five digits are the suffix, unique to each verification kit.

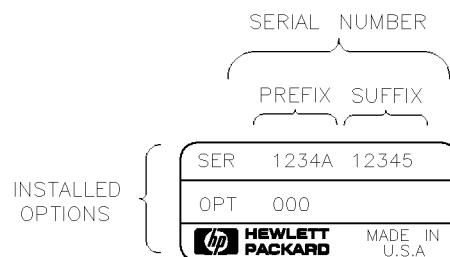

Figure 1-1. Typical Kit Serial Number Label

Device Serial Numbers

In addition to the kit serial number, the devices in this kit are individually serialized (serial numbers are either labeled on or scribed onto the body of each device). Record these serial numbers in Table 1-1. This can help you avoid confusing the devices in this kit with similar devices from other kits. Kit integrity is an important part of compliance with U.S. MIL-STD 45662A, should you need to comply with this standard.

Table 1-1. Kit and Device Serial Number Record

Device	Serial Number
Verification Kit	_____
20 dB Attenuator	_____
40 dB Attenuator	_____
50 Ω Airline	_____
25 Ω Mismatch airline	_____

Incoming Inspection

Refer to Figure 7-1 to verify a complete shipment. Use Table 1-1 to record the serial numbers of all serialized devices in your kit. To verify the electrical performance of the devices in this kit, see Chapter 5, “Performance Verification.”

If any of the following conditions exist, notify your nearest Hewlett-Packard office:

- The verification devices do not pass performance verification and cleaning and reconnecting them does not correct the problem.
- The shipping contents are incomplete.
- There is mechanical damage or defect.

The foam-lined storage case provides protection during shipping. If the case or any device appears damaged, contact the nearest Hewlett-Packard sales and service office. Hewlett-Packard will arrange for repair or replacement of incomplete or damaged shipments without waiting for a settlement from the transportation company. When you send the kit or device to Hewlett-Packard, include a service tag (found at the end of this manual) on which you provide the following information:

- Your company name and address.
- A technical contact person within your company, and the person’s complete phone number.
- If you are returning a complete kit, include the model number and serial number.
- If you are returning one or more devices, include the part numbers and serial numbers.
- Indicate the type of service required.
- Include any applicable information.

Precision Slotless Connectors

The female 3.5 mm connectors in this verification kit are metrology-grade, precision slotless connectors (PSC). A characteristic of metrology-grade connectors is direct traceability to national measurement standards through their well-defined mechanical dimensions.

Conventional female center conductors are slotted. When mated, the female center conductor is flared by the male pin. Because physical dimensions determine connector impedance, electrical characteristics of the female connector (and connection pair) are dependent upon the mechanical dimensions of the male pin. While connectors are used in pairs, their male and female halves are always specified separately as part of a standard, instrument, or device under test. Because of these facts, making precision measurements with the conventional slotted connector is very difficult, and establishing a direct traceability path to primary dimensional standards is nearly impossible.

The precision slotless connector was developed to eliminate these problems. All PSCs are female. A PSC incorporates a center conductor with a solid cylindrical shell that defines the outside diameter of the female center pin. Its outside diameter and, therefore, the impedance in its region does not change. The inner part provides an internal contact that flexes to accept the allowed range of male pin diameters.

The calibration of a network analyzer having a conventional slotted female connector on the test port remains valid only when the device under test and all calibration standards have identical male pin diameters. For this reason PSC test port adapters are supplied in most Hewlett-Packard calibration kits.

Precision slotless connectors have the following characteristics:

- There is no loss of traceable calibration on test ports when the male pin diameter of the connector on the device under test is different from the male pin diameter of the calibration standard.
- The female PSC and its mating male connector can be measured and specified separately as part of the device either is attached to.
- All female connectors can have a known, stable impedance based only on the diameters of their inner and outer conductors.
- Female calibration standards can be fully specified. Their specifications and traceability are unaffected by the diameter of the male mating pin.
- A fully traceable performance verification is made using a precision 50 Ω airline having a PSC.
- Measurement repeatability is enhanced due to non-changing connector characteristics with various pin diameters.

With PSCs on test ports and standards, the percentage of accuracy achieved when measuring at 50 dB return loss levels is comparable to using conventional slotted connectors measuring devices having only 30 dB return loss. This represents an accuracy improvement of about 10 times.

Preventive Maintenance

The best techniques for maintaining the integrity of the devices in this kit include routine visual inspection and cleaning, and proper gaging and connection techniques. Failure to detect and remove dirt or metallic particles on a mating plane surface can degrade repeatability and accuracy and can damage any connector mated to it.

Visual inspection, cleaning techniques, proper gaging, and connection techniques are all described in Chapter 4, “Gaging and Making Connections.” Poor connection techniques can also damage these devices.

Specifications

Environmental Requirements

Table 2-1. Environmental Requirements

Parameter	Required Values/Ranges
Operating Temperature	20° to 26°C (68° to 79°F)
Accuracy Enhanced Operating Temperature:	±1°C (1.8°F) of measurement calibration temperature
Altitude	
Operation	< 4,500 meters (≈15,000 feet)
Storage	< 15,000 meters (≈50,000 feet)
Relative Humidity	Always Non-Condensing
Operation	0 to 80% (26°C maximum dry bulb)
Storage	0 to 90%

Temperature – What To Watch Out For

Due to the small dimensions of the devices, electrical characteristics will change with temperature. Therefore, the operating temperature is a critical factor in their performance, and must be stable before use.

Remember Your fingers are a heat source, so avoid handling the devices unnecessarily during use.

Performance verification and measurements of devices under test need not be performed within the operating temperature range of the calibration devices, but they must be within the error-corrected temperature of the network analyzer ($\pm 1^\circ\text{C}$ of the measurement calibration temperature). For example, if the calibration is performed at $+20^\circ\text{C}$, the error-corrected temperature range is $+19^\circ$ to $+21^\circ\text{C}$. It is then appropriate to perform measurements and performance verifications at $+19^\circ$, which is outside the operating temperature range of the calibration devices, since only the actual calibration must be performed within the operating temperature range.

Mechanical Characteristics

Center Conductor Protrusion

Mechanical characteristics such as center conductor protrusion are *not* performance specifications. They are, however, important supplemental characteristics related to electrical performance. Hewlett-Packard verifies the mechanical characteristics of the devices in this kit with special gaging processes and electrical testing. This ensures that the device connectors do not exhibit any center conductor protrusion when the kit leaves the factory.

Chapter 4, “Gaging and Making Connections”, explains how to use the gages provided in this kit to determine if the kit devices have maintained their mechanical integrity.

Duplicating Your Verification Data

Duplicating the Verification Disk Using an HP 8510C

Use the following procedure to make a backup copy of the data disk using an HP 8510C network analyzer. If you are using another network analyzer, refer to its operating and service manual.

1. Initialize a blank disk:
 - a. Insert a blank disk into the HP 85101 disk drive and press **TAPE/DISC**.
 - b. Select **STORAGE IS INTERNAL SETUP DISC INITIALIZE DISC YES**.
2. Insert the **original** data disk (it came in your verification kit) in the HP 85101 disk drive.
3. Press **TAPE/DISC** and select **LOAD MEMORY ALL**. After you note the file numbers that have an asterisk next to them select **FILE 1**.
4. When file 1 is through loading, remove the **original** disk and insert the blank, initialized disk into the disk drive.
5. Duplicate the S-parameters:
 - a. Press **TAPE/DISC** and select **STORE MEMORY ALL FILE 1**.
 - b. Repeat steps 2 through 5a, substituting the next file number with an asterisk (noted in step 3) for **FILE 1** until all the files with an asterisk are copied on the new disk.
6. Duplicate the uncertainty limits:
 - a. Insert the **original** data disk in the disk drive.
 - b. Press **LOAD** and select **LOAD MEMORY 1-8**. Note the memory locations that have an asterisk next to them and select **1**.
 - c. Note the file numbers that have an asterisk next to them and select **FILE 1**.
 - d. When file 1 memory location 1 is through loading, remove the **original** disk and insert the blank, initialized disk into the disk drive.
 - e. Press **TAPE/DISC** and select **STORE MEMORY 1-8 1 FILE 1**.
 - f. Repeat steps 6a through 6e substituting the appropriate memory locations (noted in step 6b) and files (noted in step 6c) until all files in all memory locations are copied on the new disk.

7. Verify the the new disk has duplicated properly:
 - a. Press **TAPE/DISC** and select **DIRECTORY**. The screen displays four MEMORY ALL files and four MEMORY 1-8 files.
8. Remove the data disk from the disk drive.
9. Write-protect the disk and label it.

Duplicating the Verification Tape (option 002) Using an HP 8510A/B

Use the following procedure to make a backup copy of the data tape (option 002) using an HP 8510 or HP 8722 network analyzer. If you are using another network analyzer, refer to its operating and service manual.

CAUTION A tape duplicated on an HP 8510B can be used ONLY on an HP 8510B. A tape duplicated on an HP 8510A can be used on either an HP 8510A or HP 8510B.

If you will be using both an HP 8510A and HP 8510B, duplicate the tape on the HP 8510A.

1. Initialize a blank tape:
 - a. Insert a blank tape into the HP 85101 tape drive and press **TAPE/DISC**.
 - b. Select **STORAGE IS TAPE INITIALIZE TAPE INITIALIZE TAPE YES**.
2. Insert the original data tape (it came in your verification kit) in the HP 85101 tape drive.
3. Press **TAPE/DISC** and select **LOAD MEMORY ALL**. After you note the file numbers that have an asterisk next to them, select **FILE 1**.
4. When file 1 is through loading, remove the original tape and insert the blank, initialized tape into the tape drive.
5. Duplicate the S-parameters:
 - a. Press **TAPE/DISC** and select **STORE MEMORY ALL FILE 1**.
 - b. Repeat steps 2 through 5a, substituting the next file number with an asterisk (noted in step 3) for **FILE 1** until all the files with an asterisk are copied on the new tape.
6. Duplicate the uncertainty limits:
 - a. Insert the original data tape (option 002) in the tape drive.
 - b. Press **LOAD** and select **LOAD MEMORY 1-8**, (**MEMORY 1-4** on an HP 8510A). Note the memory locations that have an asterisk next to them and select **1**.
 - c. Note the file numbers that have an asterisk next to them and select **FILE 1**.

- d. When file 1 memory location 1 is through loading, remove the original tape (option 002) and insert the blank, initialized tape into the tape drive.
 - e. Press **TAPE/DISC** and select **STORE MEMORY 1-8**, (**MEMORY 1-4** on an HP 8510A) **1 FILE 1**.
 - f. Repeat steps 6a through 6e, substituting the appropriate memory locations (noted in step 6b), and files (noted in step 6c) until all files in all memory locations are copied on the new tape.
7. Verify that the new tape has duplicated properly:
 - a. Press **TAPE/DISC** and select **DIRECTORY**. The screen displays four MEMORY ALL files and four MEMORY 1-8, (**MEMORY 1-4** on an HP 8510A) files.
 8. Remove the data cartridge from the tape drive.
 9. Push the RECORD tab to the non-record position, and label the tape.

Duplicating the Verification Disk Using an HP 8719 and HP 8720-series

Two procedures that follow describe how to make a backup copy of the data disk. The first procedure is fast, but requires an HP series 200/300 controller, and an HP 9122D/S disk drive. The second procedure requires an HP 8719 and HP 8720 network analyzer, and an HP 9122D/S disk drive. Table 3-1 is a checklist of files to check off as each verification file is loaded using the second procedure.

Using the Series 200/300 Controller:

1. Load the BASIC operating system into the controller memory.
2. The master disk must be write protected. To write protect the disk, place the tab at the bottom edge of the disk. The small square should be open (you should be able to see through the square). The blank disk must be write enabled.
3. Place the blank disk in drive "O".
4. Place the master disk in drive "1".
5. Type: INITIALIZE":,700,0" to initialize the blank disk.
6. Type the following to copy the entire disk:
COPY ":,700,1" to ":,700,0"

Using the HP 8719 and HP 8720

1. The master disk must be write protected. To write protect the disk, place the tab at the bottom edge of the disk. The small square should be open (you should be able to see through the square). The blank disk must be write enabled.
2. Press **PRESET** on the analyzer.
3. Place the blank disk in drive 0.
4. Place the master disk in drive 1.
5. Press the following keys on the analyzer to initialize the blank disk:

LOCAL **SYSTEM CONTROLLER**. The analyzer is now controlling the disk drive.

DISK UNIT NUMBER **0** **x1** to select the blank disk.

SAVE **STORE TO DISK** **DEFINE STORE** **INITIALIZE DISK** **YES**. The blank disk is now initialized.

6. Press the following keys to get the first set of files from the master disk:

LOCAL **DISK UNIT NUMBER** **1** **x1**

RECALL **LOAD FROM DISK** **READ FILE TITLES**. The first set of file titles is now displayed beside the softkeys.

7. Press the following keys to load the first file into the analyzer:

LOCAL **DISK UNIT NUMBER** **1** **x1**

RECALL **LOAD FROM DISK**

LOAD (filename)

8. Press the following keys to store the first file onto the blank disk:

LOCAL **DISK UNIT NUMBER** **0** **x1**

SAVE **STORE TO DISK**

STORE (filename)

9. This sequence has transferred the first file from the master disk to the blank disk. Check off the first file on the checklist. Repeat steps 7 and 8 to transfer the other four titles shown on the softkey labels.
10. Repeat steps 6, 7, and 8 until all twelve sets of files have been transferred.

Table 3-1.

<input type="radio"/> SV1N1T	<input type="radio"/> SV3S11PB
<input type="radio"/> SV1S11MB	<input type="radio"/> SV3S11PS
<input type="radio"/> SV1S11MS	<input type="radio"/> SV3S21MB
<input type="radio"/> SV1S11PB	<input type="radio"/> SV3S21MS
<input type="radio"/> SV1S11PS	<input type="radio"/> SV3S21PB
<input type="radio"/> SV1S21MB	<input type="radio"/> SV3S21PS
<input type="radio"/> SV1S21MS	<input type="radio"/> SV3S12MB
<input type="radio"/> SV1S21PB	<input type="radio"/> SV3S12MS
<input type="radio"/> SV1S21PS	<input type="radio"/> SV3S12PB
<input type="radio"/> SV1S12MB	<input type="radio"/> SV3S12PS
<input type="radio"/> SV1S12MS	<input type="radio"/> SV3S22MB
<input type="radio"/> SV1S12PB	<input type="radio"/> SV3S22MS
<input type="radio"/> SV1S12PS	<input type="radio"/> SV3S22PB
<input type="radio"/> SV1S22MB	<input type="radio"/> SV3S22PS
<input type="radio"/> SV1S22MS	<input type="radio"/> SV4S11MB
<input type="radio"/> SV1S22PB	<input type="radio"/> SV4S11MS
<input type="radio"/> SV1S22PS	<input type="radio"/> SV4S11PB
<input type="radio"/> SV2S11MB	<input type="radio"/> SV4S11PS
<input type="radio"/> SV2S11MS	<input type="radio"/> SV4S21MB
<input type="radio"/> SV2S11PB	<input type="radio"/> SV4S21MS
<input type="radio"/> SV2S11PS	<input type="radio"/> SV4S21PB
<input type="radio"/> SV2S21MB	<input type="radio"/> SV4S21PS
<input type="radio"/> SV2S21MS	<input type="radio"/> SV4S12MB
<input type="radio"/> SV2S21PB	<input type="radio"/> SV4S12MS
<input type="radio"/> SV2S21PS	<input type="radio"/> SV4S12PB
<input type="radio"/> SV2S12MB	<input type="radio"/> SV4S12PS
<input type="radio"/> SV2S12MS	<input type="radio"/> SV4S22MB
<input type="radio"/> SV2S12PB	<input type="radio"/> SV4S22MS
<input type="radio"/> SV2S12PS	<input type="radio"/> SV4S22PB
<input type="radio"/> SV2S22MB	<input type="radio"/> SV4S22PS
<input type="radio"/> SV2S22MS	
<input type="radio"/> SV2S22PB	
<input type="radio"/> SV2S22PS	
<input type="radio"/> SV3S11MB	
<input type="radio"/> SV3S11MS	

Gaging and Making Connections

Electrostatic Discharge

Protection against ESD (electrostatic discharge) is essential while cleaning, inspecting, or connecting connectors attached to a static-sensitive circuit (such as those found in test sets).

Static electricity builds up on the body and can easily damage sensitive internal circuit elements when discharged by contact with the center conductor. Static discharges too small to be felt can nevertheless cause permanent damage. Devices such as calibration components and devices under test can also carry an electrostatic charge.

- Always have a grounded antistatic mat in front of your test equipment and wear a grounded wrist strap attached to it.
- Ground yourself before you clean, inspect, or make a connection to a static-sensitive device or test port. You can, for example, grasp the grounded outer shell of the test port briefly to discharge static from your body.
- Discharge static electricity from a device before connecting it: touch the device briefly (through a resistor of at least 1 M Ω) to either the outer shell of the test port or to another exposed ground. This discharges static electricity and protects test equipment circuitry.

Refer to Chapter 7, “Replaceable Parts”, for information on ordering supplies for ESD protection.

Visual Inspection

Visual inspection and, if necessary, cleaning should be done every time a connection is made. Metal particles from the connector threads may fall into the connector when it is disconnected. One connection made with a dirty or damaged connector can damage both connectors beyond repair.

In some cases, magnification is necessary to see damage on a connector. This is especially true with female connectors. The contact fingers on slotted connectors and on the inner contact of slotless connectors may become bent or broken. The use of a microscope with a magnification $\geq 10\times$ is recommended to detect this type of damage. Not all defects that are visible only under magnification will affect the electrical performance of the connector. Use the following guidelines when evaluating the integrity of a connector.

Obvious Defects or Damage

Examine the connectors first for obvious defects or damage: badly worn plating, deformed threads or bent, broken, or misaligned center conductors. Connector nuts should move smoothly and be free of burrs, loose metal particles, and rough spots.

Any connector that has obvious defects should be discarded or sent for repair.

Mating Plane Surfaces

Flat contact between the connectors at all points on their mating plane surfaces is required for a good connection. Look especially for deep scratches or dents, and for dirt and metal particles on the connector mating plane surfaces.

Also look for bent or rounded edges on the mating plane surfaces of the center and outer conductors and for signs of damage due to excessive or uneven wear or misalignment.

Light burnishing of the mating plane surfaces is normal, and is evident as light scratches or shallow circular marks distributed more or less uniformly over the mating plane surface. Other small defects and cosmetic imperfections are also normal. None of these affect electrical or mechanical performance.

If a connector shows deep scratches or dents, particles clinging to the mating plane surfaces, or uneven wear, clean and inspect it again. Damaged connectors should be discarded or sent for repair. Try to determine the cause of damage before connecting a new, undamaged connector in the same configuration.

Precision Slotless Connectors

Precision slotless female connectors are used to improve accuracy. The slotless contacts are not affected by the slight variations in male contact pin diameter, however, it is still advisable to inspect them regularly for damage.

Connector Wear

Connector wear eventually degrades performance. The more use a connector gets, the faster it wears and degrades. The wear is greatly accelerated when connectors are not kept clean. Replace all worn connectors.

Cleaning Connectors

For details on cleaning connectors, see “Principles of Microwave Connector Care—Quick Reference Card” located in the back of this manual. Refer to Chapter 7, “Replaceable Parts”, for the HP part number if another copy is needed.

Specifications

At the factory, each verification device is electrically characterized on a network analyzer measurement system. These factory measurements are traceable to the National Institute of Standards and Technology (NIST) through mechanical and electrical paths (for more information on traceability, contact your nearest Hewlett-Packard office).

The factory-measured data for each device is supplied in printed, disk, and tape (option 002) form with your kit.

Supplemental Characteristics

The following tables list the dimensions of the 50 Ω airline and the 25 Ω mismatch airline. These are supplemental mechanical characteristics, and from these characteristics you can calculate expected electrical performance.

CAUTION The center and outer conductors of the airlines in this kit have been mechanically measured and matched. *Do not* use the center or outer conductors provided in this kit with a center or outer conductor from any other airline. *Damage to the airline or attaching connector may result.*

Center Conductor Protrusion

No center conductor shoulder (male pin end of female center pin) protrusion is allowable on any fixed center conductor 3.5 mm connector

Center Conductor Recession

The devices in this kit have been electrically characterized at the factory. The characterization data accounts for the actual recession of each device.

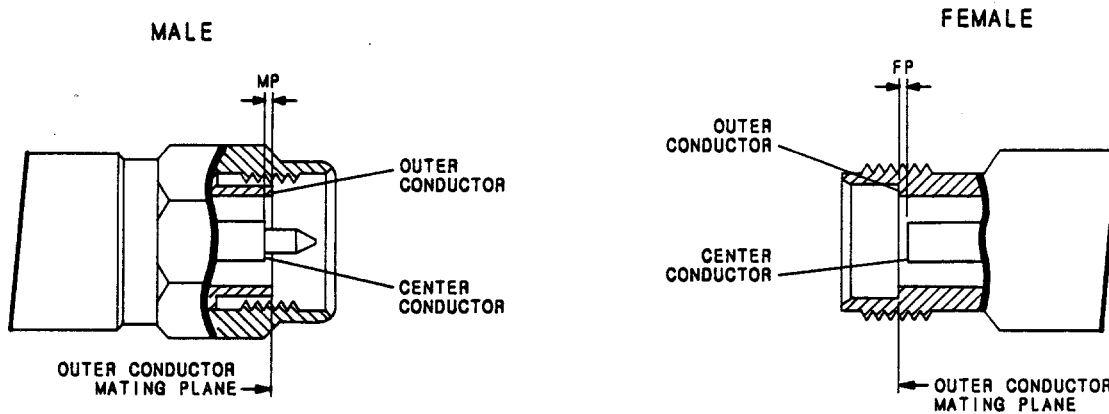

Figure 4-1. 3.5 mm Attenuators

MP = male contact pin shoulder recession behind the outer conductor mating plane.

FP = recession of the end of female center pin behind the outer conductor mating plane.

Table 4-1.

Connectors	Allowable Recession	
	millimeters	inches
Attenuators	0.000 to 0.08	0.0000 to 0.003
Airlines ¹	+0.0025 to -0.010	+0.0001 to -0.0004

¹ The relationship between the length of the inner conductor and the length of the outer conductor determines the airline center conductor recession. See this chapter for airline gaging instructions.

Using these mechanical dimensions, you can calculate the expected electrical performance with the equations in the following Publications:

- Nelson, Robert E., and Marlene R. Coryell, “Electrical Parameters of Precision, Coaxial, Air-Dielectric Transmission Lines”, U.S. National Bureau of Standards Monograph No. 96.
- Somlo, P.I., “The Computation of Coaxial Line Step Capacitances”, IEEE Transactions on Microwave Theory and Techniques, Volume MTT-15, No. 1, January, 1967.

The measurement method in these publications provides a general idea of the expected device characteristic impedance. Variations in connector interfaces can have a large effect on your actual electrical measurements.

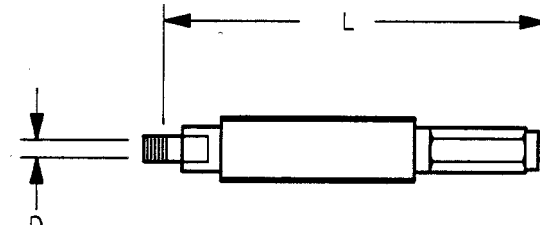

Figure 4-2.
Outer Conductor
(Common to Both Airlines)

Table 4-2.

Dimension	millimeters	inches
D = Diameter	3.500 ±0.004	0.1378 ±0.00016
L = Length	74.924 ±0.025	2.950 ±0.001

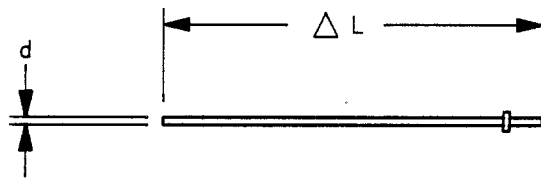

Figure 4-3. 50 Ω Airline Center conductor

Table 4-3.

Dimension	millimeters	inches
d = Diameter	1.52 ±0.003	0.0598 ±0.0001
ΔL = L - Length Variation ¹	-0.0004/-0.010	+0.0001/-0.0025

¹ The difference between the center conductor length and the outer conductor length.

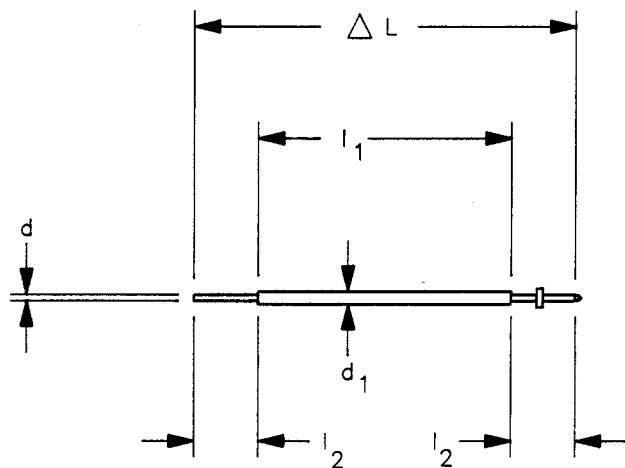

Figure 4-4. 25 Ω Mismatch Airline Center Conductor

Table 4-4.

Dimension	millimetres	inches
$d =$	2.306 ± 0.005	0.0908 ± 0.0002
$d = ??$	1.52 ± 0.008	0.0598 ± 0.0003
$l_1 =$	49.943 ± 0.019	1.9663 ± 0.0007
$l_2 =$	12.521 ± 0.050	0.4930 ± 0.002
$\Delta L = L$	$+0.0025/-0.010$	$+0.0001/-0.0004$

Gaging Connectors

Gage Intent

The gages required for this kit (see “Replaceable Parts”), are intended for preventive maintenance and troubleshooting purposes only. They are effective in detecting *excessive* center conductor protrusion or recession and connector damage on DUTs, test accessories, and the calibration kit devices. They are especially useful in determining if the pin depths of sliding loads are grossly out of adjustment. *Do not use gages for precise pin depth measurements.*

Gage Accuracy

The connector gages are only capable of performing coarse measurements. They do not provide the degree of accuracy necessary to precisely measure the pin depth of the kit devices. This is partially due to the repeatability uncertainties that are associated with the measurement. Only the factory, through special gaging processes and electrical testing, can accurately verify the mechanical characteristics of the devices.

With proper technique, however, the gages are useful in detecting gross pin depth errors on device connectors. To achieve maximum accuracy, random errors must be reduced by taking the average of at least three measurements having different gage orientations on the connector. Even then, the resultant average can be in error by as much as ± 0.0001 inch due to systematic (biasing) errors usually resulting from worn gages and gage masters.

When to Gage Connectors

Gage a connector at the following times:

- Before you use it the first time. It is recommended that you record the initial pin depth measurement of the device to compare with future readings. This serves as a good troubleshooting tool when you suspect damage may have occurred to the device.
- If either visual inspection or electrical performance suggests that the connector interface may be out of typical range (due to wear or damage, for example).
- If a verification device is used by someone else or on another system or piece of equipment.
- As a matter of routine; initially after every 100 connections, and after that as often as experience suggests.

Zeroing the Gage

Note Hold a connector gage by the gage barrel, below the dial indicator. This gives the best stability, and improves measurement accuracy (cradling the gage in your hand or holding it by the dial applies stress to the gage plunger mechanism through the dial indicator housing).

1. Select the proper gage for your connector. The gages are intended for performing 3.5 mm pin depth measurements.
2. Inspect and clean the gage:
 - a. Inspect the connector gage and the gage master carefully, exactly as you inspected the connector itself.
 - b. Clean or replace the gage and the gage master if necessary. Dirt on either the gage or the gage master makes gage measurements inaccurate, and can damage a connector.
3. Zero the connector gage.
 - a. While holding the gage by the plunger barrel, use the connecting knurl to screw on the gage master just until you meet resistance.
 - b. Use a torque wrench to tighten the connecting nut of the gage master.
 - c. As you watch the gage pointer, gently tap the barrel of the gage with your finger to settle the reading.

The gage pointer should line up exactly with the zero mark on the gage. If not, adjust the zero set knob until the gage pointer exactly lines up with zero.

Note Check gages often to make sure that the zero setting has not changed. Generally, when the pointer on a recently zeroed gage does not line up exactly with the zero mark, the gage or gage master needs cleaning. Clean both of these carefully and check the zero setting again.

How To Assemble an Airline

CAUTION To avoid damaging an airline or attaching connector, do NOT use a center or outer conductor from this kit with a center or outer conductor from any other airline. The center and outer conductors in this kit have been mechanically measured and matched according to length.

Assemble both the 50 Ω airline and the 25 Ω mismatch airline as follows:

1. Remove the protective cap from the female end of the outer conductor. Leave the protective cap on the male end to prevent the center conductor from falling out (in step 3).
2. Remove the center conductor from its plastic case.

3. Insert the male end of the center conductor all the way into the outer conductor; the female end of the center conductor is toward the end of the outer conductor without the connector nut see Figure 4-5.
4. Until you are ready to use the airline, replace the protective cap on the female end.

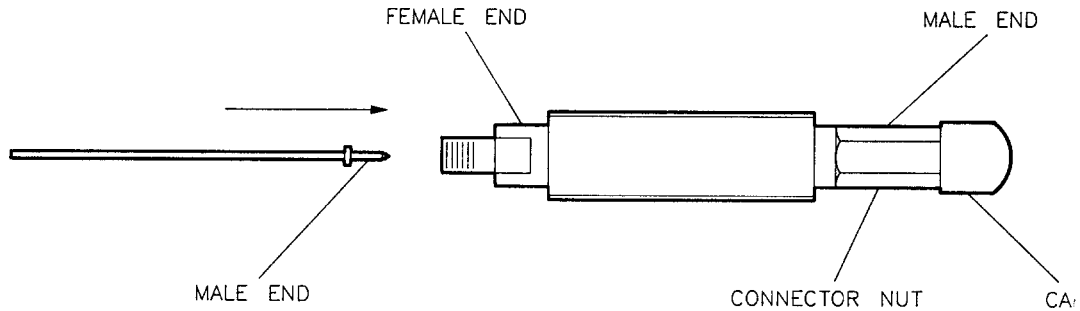

Figure 4-5. Airline Center Conductor Placement

Connect the Airline:

1. Ensure that cables are connected to port 1 and port 2 (as they were connected during the calibration procedure). (Figure 4-6).

Note If possible, use an active display.

2. Remove the protective cap from the female end of the outer conductor (the end without the nut). Leave the cap on the male end for now.
3. Insert the center conductor in the proper orientation. Verify that the female end of the center conductor emerges from the end of the outer conductor without the nut.

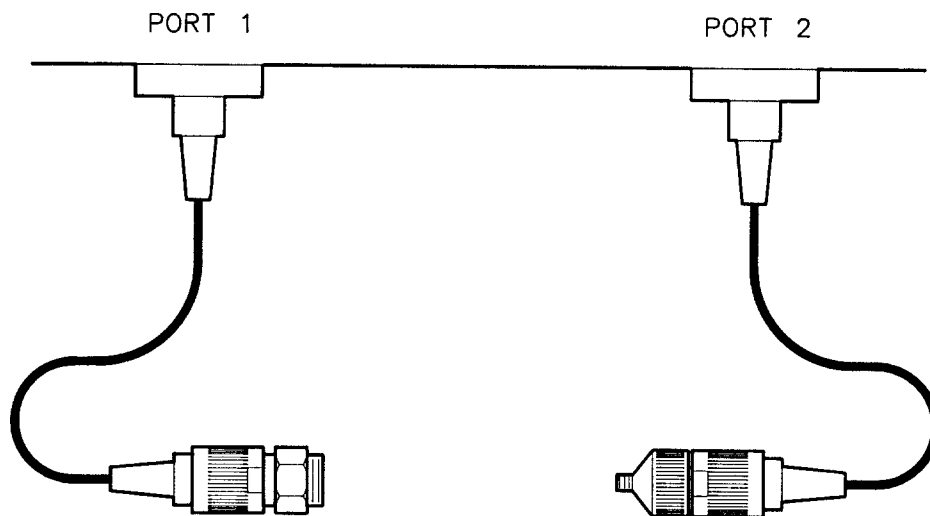

Figure 4-6. Equipment Configuration

Note To avoid damaging the airline center conductor, always keep it in line with the connecting center pin.

CAUTION During these procedures you will be touching the exposed center conductor of the test port with the center conductor of the airline. *Use ESD precautions* outlined in “Electrostatic Discharge” in this chapter.

4. Hold the airline and center conductor Figure 4-7 and bring the outer and center conductor to the cable connector. Mate the end of the airline center conductor with the center conductor of the cable connector.
 5. Connect the outer conductor of the airline to the outer conductor of the cable connector. Finger tighten, then torque to 90 N-cm (8 in-lb).
-

Note To keep the airline from turning, either hold its plastic insulation or use an open end wrench while you torque the connection Figure 4-8.

6. Remove the protective cap from the male end of the airline.
7. Insert the male end of the airline center conductor into the female end of the cable and mate the outer conductors by sliding the nut on the airline forward. Finger tighten this connection, then torque.

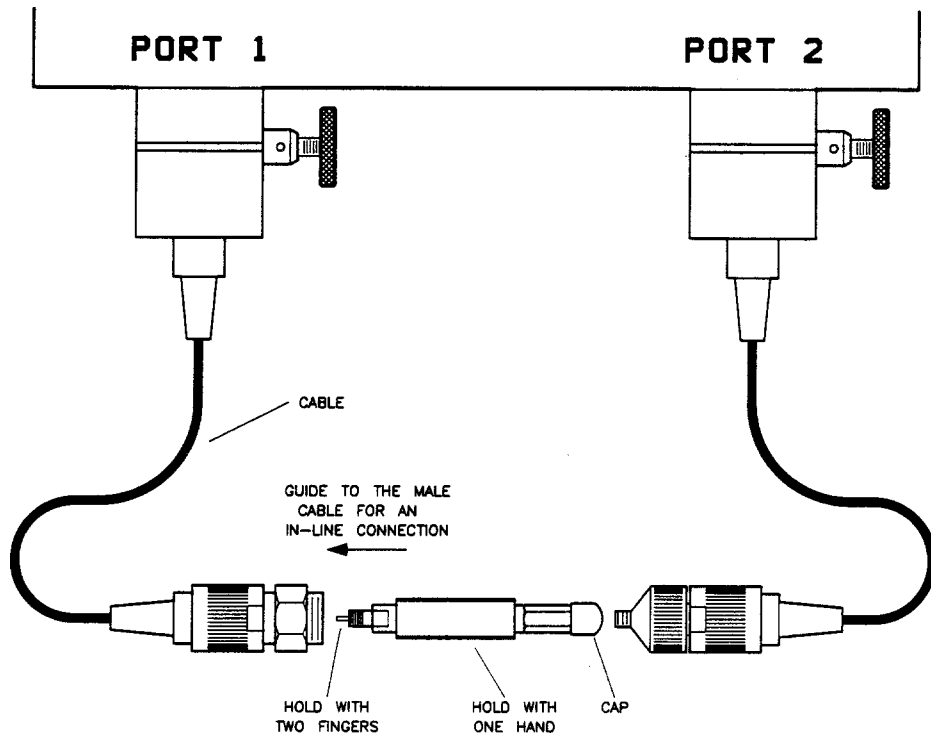

Figure 4-7. Aligning the Center Conductor

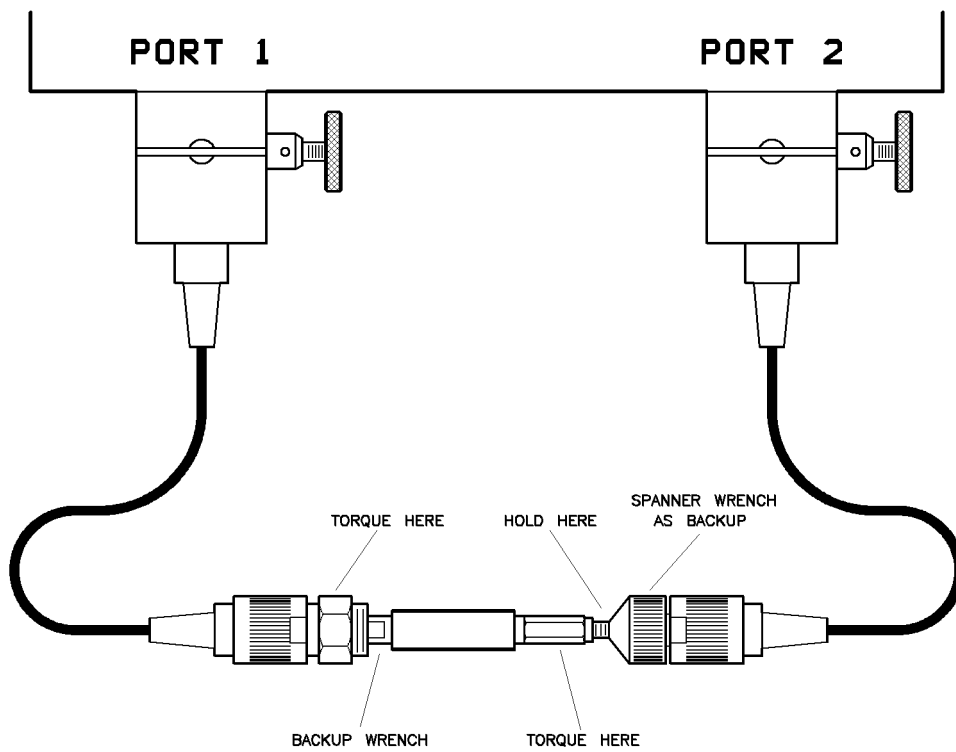

Figure 4-8. Torquing the Connection

Gage the Airline

The airlines in this kit are measured and matched for length at the factory using special fixtures and gages. Because the gages supplied in the calibration kits do not have the accuracy of the factory gages, use the following procedure for very general results only. If, for example, you suspect that a center conductor has been switched with another airline, or that these delicate standards have been damaged.

Attach the airline to the gage and short circuit:

1. Inspect and, if required, clean the short, airline, and gage mating surfaces and threads.
2. Attach the male short circuit termination from your calibration kit to the gage. Torque the connection to 90 N-cm, (8 in-lb).
3. Gently tap the gage to settle the meter movement.
4. Adjust the dial on the gage to read flush (0.000) with the short circuit connected.
5. Assemble the airline and center conductor:
 - a. Remove the center conductor from its plastic case.
 - b. Remove the protective cap from the female end of the outer conductor.
 - c. Insert the male end of the center conductor (with bead) into the outer conductor. The male end of the center conductor is toward the female end of the outer conductor (without the connector nut).
6. Remove the short circuit from the gage and attach the short circuit to the female end of the airline.
7. Remove the protective cap from the male end of the airline. To seat the center conductor onto the short, carefully press the male end of the center conductor lightly against a firm flat object.

Note	Do not touch either the center or outer conductor interface to metal or any harder surface. The soft gold plating can be displaced, changing the pin depth and the performance.
-------------	---------------------------------------------------------------------------------------------------------------------------------------------------------------------------------

8. Mate the gage to the airline Figure 4-9.
9. Torque the short circuit to airline connection and the gage to airline connection. Tap the gage and set the assembly down to let the temperature stabilize for 5 minutes.

Note	The reading on the gage is an estimate of the actual recession of the center conductor. Gage accuracy is typically ± 0.0001 inch.
-------------	---------------------------------------------------------------------------------------------------------------------------------------

Disconnect the airline from the gage and short circuit:

10. Remove one device from the airline and replace the plastic cap on the airline to prevent the center conductor from sliding out of the outer conductor.

If the airline center conductor does not disengage from the device center conductor, gently pull the airline center conductor from the device center conductor and push the airline center conductor back inside the outer conductor of the airline.

11. Remove the device from the other end of the airline. If you won't be using the airline again immediately, slide the center conductor out of the outer conductor and store the center conductor in the plastic case provided. Replace the other plastic cap on the outer conductor and store the center and outer conductors in the foam lined storage case.

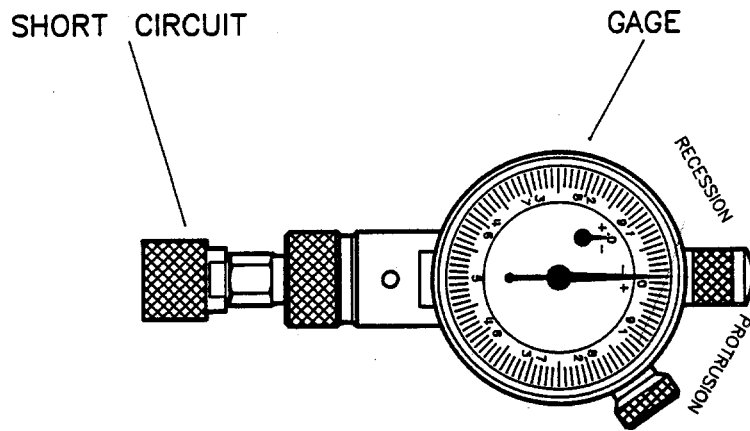

Figure 4-9. Gaging the Short Circuit

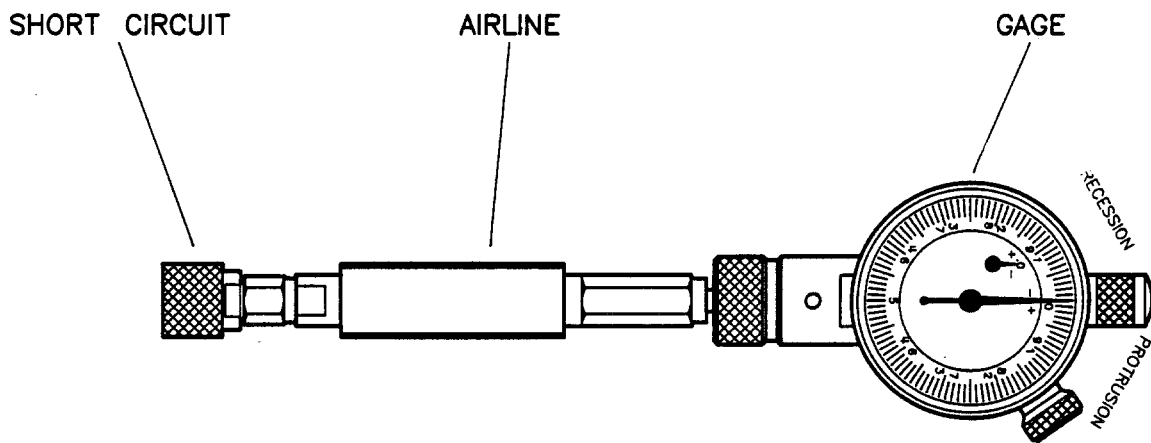

Figure 4-10. Gaging the Airline

Disconnect the Airline:

1. Remove one cable from the airline and replace the plastic cap on the airline to prevent the center conductor from sliding out of the outer conductor.
2. Remove the cable from the other end of the airline. If you will not be using the airline again immediately, slide the center conductor out of the outer conductor and store the center conductor in the plastic case provided. Replace the other plastic cap on the outer conductor and store the center and outer conductors in the foam lined storage case.

Connections

Good connections require a skilled operator. Instrument sensitivity and coaxial connector mechanical tolerances are such that slight errors in operator technique can have a significant effect on measurements and measurement uncertainties.

Remember *The most common cause of measurement error is poor connections.*

Follow these recommendations for optimum connection technique:

- Clean and inspect (visually and mechanically) all connectors.
- Align connectors carefully. Look for flat physical contact at all points on the mating plane surfaces.
- Make a gentle, preliminary connection.
- When you make a connection, turn *only* the connector nut. Do not rotate a device when you make a connection and do not apply lateral or horizontal (bending) force.
- Use an open-end wrench to keep the device from rotating when making the final connection with the torque wrench (see Figure 4-11).

Connection Procedure

1. Ground yourself and all devices (wear a grounded wrist strap and work on an antistatic mat).
2. Visually inspect the connectors.
3. If necessary, clean the connectors.
4. Carefully align the connectors.

The male connector center pin must slip concentrically into the contact fingers of the female connector.

5. Push the connectors straight together. Do *not* twist or screw them together. As the center conductors mate, there is usually a slight resistance.

CAUTION Do *not* twist one connector into the other (like inserting a light bulb). This happens if you turn the device body rather than the connector nut. Major damage to the center conductor can occur if the device body is twisted.

6. The preliminary connection is tight enough when the mating plane surfaces make uniform, light contact. Do not overtighten this connection.

At this point all you want is a connection in which the outer conductors make gentle contact at all points on both mating surfaces. Very light finger pressure (no more than 2 inch-pounds of torque) is enough.

7. Relieve any side pressure on the connection from long or heavy devices or cables. This assures consistent torque in the following steps.

Using the Torque Wrench

1. Use the 8 in-lb torque wrench supplied with the calibration kit to make the final connection. Table 4-5 provides information on the torque wrench required for the connector type found in this kit.

Table 4-5. Torque Wrench Information

Connector Type	Torque Setting	Torque Tolerance
3.5 mm	90 N-cm (8 in-lb)	± 5.6 N-cm ($\pm 10\%$)

Using the torque wrench guarantees that a connection is not too tight, preventing possible connector damage. It also guarantees that all connections are equally tight each time.

2. Roatate *only* the connector nut when you tighten the connector. In all situations, the use of an open-end wrench to keep the body of the device from turning is recommended. Position both wrenches within 90 degrees of each other before applying force. Wrenches opposing each other (180 degrees apart) will cause a *lifting action* which can misalign and stress the connections of the devices involved. This is especially true when several devices are connected together (see Figure 4-11).

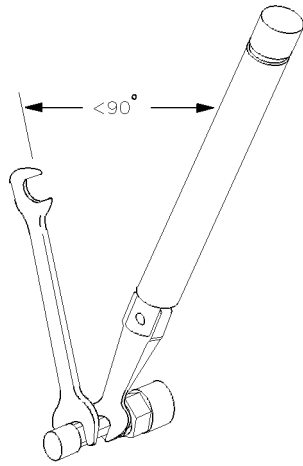

wj67d

Figure 4-11. Correct Wrench Position

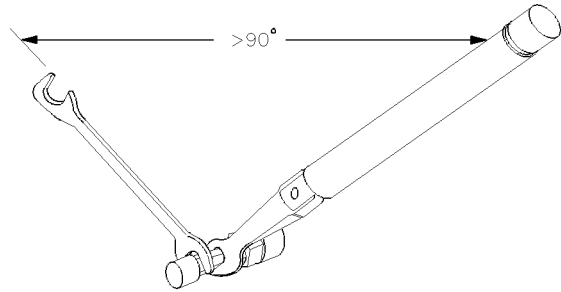

wj613d

Figure 4-12. Incorrect Wrench Position

3. Hold the torque wrench lightly, at the end of the handle only (beyond the groove). (see Figure 4-13).

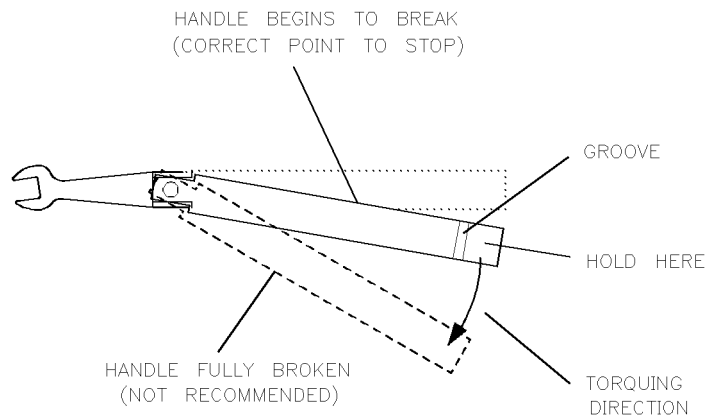

Figure 4-13. Using the Torque Wrench

4. Apply force perpendicular to the wrench handle. This applies torque to the connection *through* the wrench.

Do *not* hold the wrench so tightly that you push the handle straight down along its length rather than pivoting it, otherwise you apply an unlimited amount of torque.

5. Tighten the connection just to the torque wrench “break” point (see Figure 4-13). Do *not* tighten the connection further.

CAUTION You don't have to "fully break" the handle of the torque wrench to reach the specified torque; doing so can cause the handle to kick back and loosen the connection. Any give *at all* in the handle is sufficient torque.

Do *not* pivot the wrench handle on your thumb or other fingers, otherwise you apply an unknown amount of torque to the connection when the wrench reaches its "break" point.

Do *not* twist the head of the wrench relative to the outer conductor mating plane. If you do, you apply more than the recommended torque.

Disconnection Procedure

Note To avoid lateral (bending) force on the connector mating plane surfaces, always support the devices and connections.

1. Use an open-end wrench to prevent the device body from turning.
 2. Use another wrench to loosen the connector nut.
 3. Complete the disconnection by hand, turning only the connector nut.
-

CAUTION Do *not* twist one connector out of the other (like removing a light bulb). Turn the connector nut, not the device body. Major damage to the center conductor can occur if the device body is twisted.

4. Pull the connectors straight apart without twisting or bending.
-

Handling and Storage

- Store verification devices in a foam-lined storage case.
- Never store connectors and airlines loose in a box, in a desk, or in a bench drawer. This is the most common cause of connector damage during storage.
- Keep connectors and airlines clean.
- Do not touch mating plane surfaces. Natural skin oils and microscopic particles of dirt are easily transferred to a connector interface and are very difficult to remove.
- Do not set connectors contact-end down on a hard surface. The plating and the mating plane surfaces can be damaged if the interface comes in contact with any hard surface.
- When you are not using a connector, use plastic end caps over the mating plane surfaces to keep them clean and protected.

Performance Verification

The performance of your verification kit can only be verified by returning the kit to Hewlett–Packard for recertification. The equipment and standards required to verify the specifications limits of the devices inside the kit have been specially manufactured and are not commercially available. Hewlett–Packard recognizes its responsibility to provide you with procedures to reconfirm the published specifications of any product offered. That commitment applies equally to the HP 85053B 3.5 mm verification kit. If it is imperative that the performance test processes for this kit be explained or made available to you, contact the nearest Hewlett–Packard sales and service office listed at the back of this manual.

What Recertification Provides

The following will be provided with a recertified kit:

- New Calibration sticker affixed to the case.
- Certificate of Calibration.
- List of NIST (United States National Institute of Standards and Technology) traceable numbers.
- A calibration report for each device in the kit listing measured values, and uncertainties.

For more information, contact the nearest Hewlett–Packard office (sales and service offices are listed in the back of this manual).

How Often to Recertify

The suggested initial interval for recertification is 12 months or sooner. The actual need for recertification depends on the use of the kit. After reviewing the results of the initial recertification, you may establish a different recertification interval that reflects the usage and wear of the kit.

Note In some cases, the first time a kit is used after being recertified occurs some time after the actual recertification date. The recertification interval should begin on the date the kit is *first used*.

Where to Send a Kit for Recertification

Contact the sales and service office nearest you for information on where to send your kit for recertification (offices are listed in the back of this manual). When you return the kit, fill out and attach a service tag. (Refer to “Returning a Kit or Device to HP” in Chapter 6, “Troubleshooting.”)

How Hewlett-Packard Verifies the Devices in this Kit

Hewlett-Packard verifies the specifications of these devices as follows:

The residual microwave error terms of the test system are verified with precision airlines and shorts, or low frequency resistance. The resistance is then directly traced back to NIST (United States National Institute of Standards and Technology). The airline and short characteristics are developed from mechanical measurements. The mechanical measurements and material properties are carefully modeled to give very accurate electrical representation. The mechanical measurements are then traced back to NIST through various plug and ring gages and other mechanical measurements.

For Manufacturing:

Each verification device is electrically measured on this test and compared to general device specifications (*not* listed in this manual). Set to insure appropriate device characteristics for the purpose of this kit.

For Customer Kit Recertification:

Each verification device is electrically measured on this test system and compared to previous measurement data to insure that the devices are stable and repeatable. Data outside of the control limits generates an out-of-tolerance report.

In both cases, if the device is acceptable, new characterization data and uncertainties are generated for it.

These two steps establish a traceable link to NIST for Hewlett-Packard to the extent allowed by the Institute's calibration facility. The devices in this kit are traceable to NIST through Hewlett-Packard.

Troubleshooting

If your network analyzer does not pass performance verification, follow the steps in Figure 6-1.

Compatible Network Analyzers

The devices in this kit and their data are compatible with HP 8510A, HP 8510B, and HP 8510C network analyzer systems. In addition, this verification kit contains a data disk for use with the HP 8719 and HP 8720-series network analyzers.

HP 8719 and HP 8720-series Network Analyzer

The data disk provided for specific use for the HP 8719 and HP 8720-series in this verification kit have a serial number prefix of 2815A or higher. Kits ordered prior to this serial prefix can be upgraded to include the data disk by recertifying the kit through a local HP sales and service office.

The verification disk contains the factory-measured S-parameter data for the devices in this kit. It also contains the uncertainty limits used in the system verification procedure for the HP 8719 and HP 8720-series. This data is unique to each kit, and is recommended that a backup copy of the data disk and the data printout are made immediately upon receiving the verification disk.

Returning a Kit or Device to HP

If your kit or device requires service, contact the HP office nearest you for information on where to send it (sales and service offices are listed in the back of this manual). When you send the kit or device to Hewlett-Packard, include a service tag (found at the end of this manual) on which you provide the following information:

- Your company name and address.
- A technical contact person within your company, and the person's complete phone number.
- If you are returning a complete kit, include the model number and serial number.
- If you are returning one or more devices, include the part numbers and serial numbers.
- Indicate the type of service required.
- Include any applicable information.

Where To Look For More Information

This manual contains limited information about network analyzer system operation. For complete information, refer to the instrument documentation.

If you need additional information, contact your local Hewlett-Packard representatives. Sales and service offices are listed at the rear of this manual.

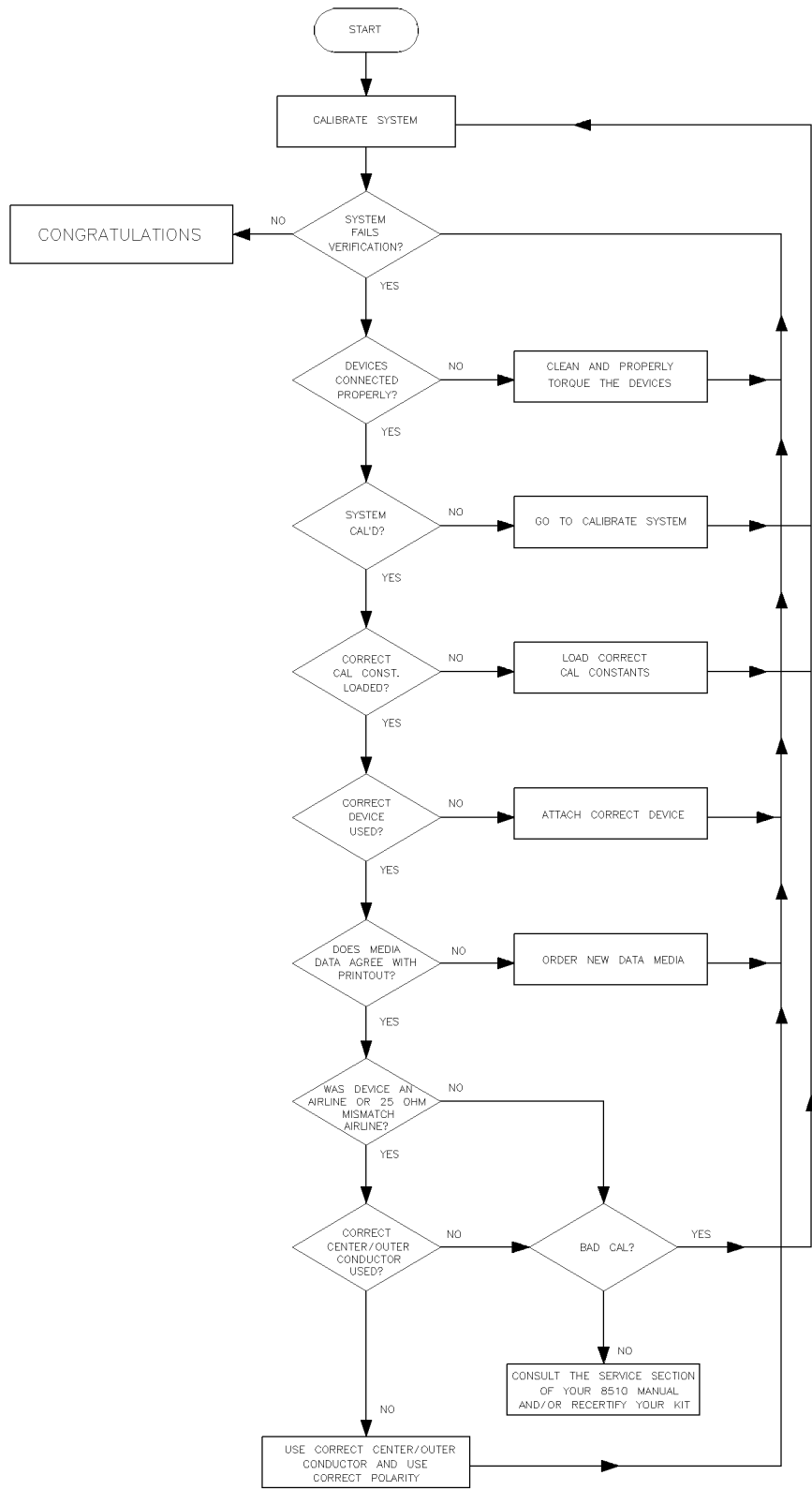

Figure 6-1. Troubleshooting Flowchart

Replaceable Parts

Table 7-1 lists the replacement part numbers for the HP 85053B verification kit contents. To order a listed part, note the description, HP part number, and the quantity desired. Telephone or send your order to the nearest Hewlett-Packard sales and service office (see the back of this manual).

Table 7-1. Replaceable Parts

Description	Qty Per Kit	HP Replacement Part Number
Attenuators		
20 dB Attenuator with data	1	85053-60001
40 dB Attenuator with data	1	85053-60002
Airlines		
50Ω Airline with data	1	85053-60008
25Ω Mismatch Airline with data	1	85053-60009
Miscellaneous Items		
Operating and Service Manual	1	85053-90028
Verification Data Tape (option 002)	1	85053-10001
Verification Data Disk (HP 8719/8720)	1	85053-10002
Verification Data Disk (HP 8510)	1	85053-10003
Storage Box Assembly	1	85053-60007
Connector Care—Quick Reference Card	1	08510-90360
Items Not Included in Kit		
5/16 in., 90 N-cm (8 in-lb) Torque ¹	1	8710-1765
5/16 mm Open-end ¹	1	8720-0015
2.4 mm (m) Gage Set ¹	1	11752-60106
2.4 mm (f) Gage Set ¹	1	11752-60105
2.4 mm Short ¹	1	85052-60006
Blank Tape (for data backup)		9164-0166
Isopropyl Alcohol (30 ml)		8500-5344
Cleaning Swabs (100)		9301-1243
Grounding Wrist Strap		9300-1367
5 ft Grounding Cord for Wrist Strap		9300-0980
2 × 4 ft Conductive Table Mat and 15 ft Ground Wire		9300-0797
ESD Heel Strap (for conductive floors)		9300-1126

¹ Included in the HP 85052B 3.5 mm Calibration Kit.

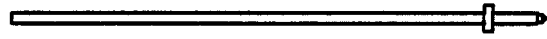

50ohm AIRLINE

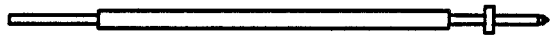
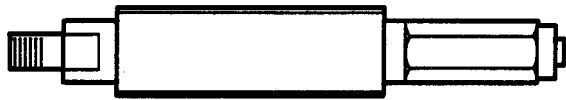

25ohm MISMATCH AIRLINE

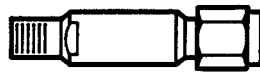

20dB ATTENUATOR

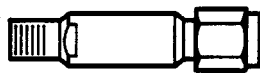

40dB ATTENUATOR

Figure 7-1. Replaceable Parts

Hewlett-Packard Sales and Service Offices

IN THE UNITED STATES

California

Hewlett-Packard Co.
1421 South Manhattan Ave.
P.O. Box 4230
Fullerton, CA 92631
(714) 999-6700

Hewlett-Packard Co.
301 E. Evelyn
Mountain View, CA 94039
(415) 694-2000

Colorado

Hewlett-Packard Co.
24 Inverness Place, East
Englewood, CO 80112
(303) 649-5000

Georgia

Hewlett-Packard Co.
2000 South Park Place
P.O. Box 105005
Atlanta, GA 30339
(404) 955-1500

Illinois

Hewlett-Packard Co.
5201 Tollview Drive
Rolling Meadows, IL 60008
(312) 255-9800

New Jersey

Hewlett-Packard Co.
120 W. Century Road
Paramus, NJ 07653
(201) 265-5000

Texas

Hewlett-Packard Co.
930 E. Campbell Rd.
Richardson, TX 75081
(214) 231-6101

IN AUSTRALIA

Hewlett-Packard Australia Ltd.
31-41 Joseph Street
Blackburn, Victoria 3130
895-2895

IN CANADA

Hewlett-Packard (Canada) Ltd.
17500 South Service Road
Trans-Canada Highway
Kirkland, Quebec H9J 2X8
(514) 697-4232

IN FRANCE

Hewlett-Packard France
F-91947 Les Ulis Cedex
Orsay
(6) 907-78-25

IN GERMAN FEDERAL REPUBLIC

Hewlett-Packard GmbH
Vertriebszentrale Frankfurt
Berner Strasse 117
Postfach 560 140
D-6000 Frankfurt 56
(0611) 50-04-1

IN GREAT BRITAIN

Hewlett-Packard Ltd.
King Street Lane
Winnersh, Wokingham
Berkshire RG11 5AR
0734 784774

IN OTHER EUROPEAN COUNTRIES

Hewlett-Packard (Schweiz) AG
Allmend 2
CH-8967 Widen (Zurich)
(0041) 57 31 21 11

IN JAPAN

Yokogawa-Hewlett-Packard Ltd.
29-21 Takaido-Higashi, 3 Chome
Suginami-ku Tokyo 168
(03) 331-6111

IN PEOPLE'S REPUBLIC OF CHINA

China Hewlett-Packard, Ltd.
P.O. Box 9610, Beijing
4th Floor, 2nd Watch Factory
Main Bldg.
Shuang Yu Shu, Bei San Huan Rd.
Beijing, PRC
256-6888

IN SINGAPORE

Hewlett-Packard Singapore
Pte. Ltd.
1150 Depot Road
Singapore 0410
273 7388
Telex HPSGSO RS34209
Fax (65) 2788990

IN TAIWAN

Hewlett-Packard Taiwan
8th Floor, Hewlett-Packard
Building
337 Fu Hsing North Road
Taipei
(02) 712-0404

IN ALL OTHER LOCATIONS

Hewlett-Packard Inter-Americas
3495 Deer Creek Rd.
Palo Alto, California 94304

Index

3

- 3.5 mm
 - connecting, 4-15

A

- adapters
 - traceability of, 1-3
- assemble, 4-1
 - 25 Ω mismatch airline, 4-8
 - 50 Ω airline, 4-8
- avoiding problems, 1-5

B

- back up using 8510C, 3-1

C

- calculate
 - expected electrical performance, 4-3
- calibration
 - certificate of, 5-1
 - temperature, 2-1
- calibration report, 5-1
- center conductor protrusion, 2-2
- Certificate of Calibration, 5-1
- characteristics
 - airlines, 4-3
- cleaning connectors, 4-3
- compatible network analyzers, 6-1
- connections, 4-1, **4-15**
- connectors
 - care of, 1-1
 - cleaning, 4-3
 - metrology-grade, 1-4
 - precision slotless, 1-4, 4-2
 - visual inspection, 4-1-2
- connector wear, 4-2

D

- data
 - recertification, 5-1
- device
 - connecting, 4-15
 - disconnecting, 4-18
 - handling, 4-18
 - storage, 4-18

- temperature, 2-1
- visual inspection, 4-1-2
- device maintenance, 1-5
- dimensions
 - 25 Ω mismatch airline, 4-3
 - 50 Ω airline, 4-3
- disconnections, 4-18
- disk backup for HP 8719 and 8720, 3-3
- documentation
 - replacement, 7-2
- duplicate disk
 - how to, 3-1
- duplicating verification data, 3-1

E

- electrostatic discharge, 4-1
- equipment required, 1-2
- ESD, 4-1
 - protection, 4-1

G

- gage
 - use, 4-8
 - zeroing of, 4-8
- gaging, 4-1
 - for troubleshooting, 4-7
 - when to, 4-7

H

- handling, 4-18
- HP 8719 network analyzer disk, 6-1
- Hp 8720-series network analyzer disk, 6-1

I

- incoming inspection, 1-3
- information
 - where to find more, 6-2
- inspection
 - damage, 4-2
 - defects, 4-2
 - incoming, 1-3
 - magnification, 4-1
 - mating plane, 4-2
 - microscope, 4-1
 - slotless connectors, 4-2

visual, 4-1-2

K

kit overview, 1-1

M

magnification, 4-1

maintenance of devices, 1-5

making a backup disk

how to, 3-1

mechanical characteristics, 2-2

mechanical tolerance, 2-2

metrology-grade connectors, 1-4

microscope, 4-1

N

network analyzers

compatible, 1-1

NIST, 5-2

O

ordering parts, 7-1

overview, of kit, 1-1

P

part numbers, 7-1

parts, replacing, 7-1

performance verification, 5-1

pin depth, 2-2

precision connectors, 1-4

prefix, serial, 1-2

preventive maintenance, 1-5

procedure using 200/300 controller, 3-3

procedure using the HP 8719 and HP 8720, 3-4

protrusion

center conductor, 2-2

PSC, 1-4

R

recertification, 5-1

how it's done, 5-2

interval, 5-1

what's included, 5-1

where it's done, 5-2

replaceable parts, 7-1

connector care supplies, 7-2

documentation, 7-2

required equipment, 1-2

requirements

environmental, 2-1

return to HP, 6-1

S

serial number, 1-2

device, 1-3

U.S. MIL-STD 45662A, 1-3

slotless connectors, 1-4, 4-2

specifications, 2-1

device, 4-3

environmental, 2-1

mechanical, 2-2

temperature, 2-1

verifying, 5-1

static discharge, 4-1

storage, 4-18

supplied verification data, 1-2

T

temperature

calibration, 2-1

device, 2-1

error-corrected temperature range, 2-1

measurement, 2-1

operating temperature range, 2-1

verification and measurement, 2-1

test data, 5-1

torque wrench, 4-16

traceability, 5-1, 5-2

troubleshooting, 6-1

U

U.S. MIL-STD 45662A

device serial numbers, 1-3

V

verification

temperature, 2-1

verification data replacement, 1-2

verification kit overview, 1-1

visual inspection, 4-1-2

W

warranty, iii